

CMC 14 Common Mode Chokes Series

High Grade - Improved Temperature Stability



- Less than 20% performance variations versus temperature (-55 °C/+125 °C)
- Minimum impedance attenuation: 100 Ω from 100 kHz to 30 MHz
- Compact SMD package (2x4 pins)
- Applied standards: MIL-STD-202, ECSS-Q-ST-70-02C, DO-160 and ESCC 3201 generic specification for space products
- Materials meet UL94-V0 rating
- Thermal index according to IEC85: H (180 °C)
- Operating/storage temperature range: -55 °C to +125 °C
- Approx weight: 5 grams

Electrical Data

ID Code	Inductance Value at 25°C (-40/+35%)	MAX RMS Current for ΔT = 40°C	MAX DC Resistance (25°C)
CMC14 M14 2WR	140 μH	7.2 A	2.7 mΩ
CMC14 M25 2WR	248 μH	6.4 A	3.5 mΩ
CMC14 M39 2WR	387 μH	5.7 A	4.4 mΩ
CMC14 M56 2WR	558 μH	5.4 A	5.0 mΩ
CMC14 M76 2WR	760 μH	4.5 A	7.0 mΩ
CMC14 M99 2WR	992 μH	3.8 A	10.0 mΩ
CMC14 1M2 2WR	1255 μH	3.2 A	14.0 mΩ
CMC14 1M5 2WR	1550 μH	2.6 A	20.0 mΩ
CMC14 2M2 2WR	2232 μH	2.2 A	29.0 mΩ

Notes

1. Dielectric strength test: 500v (50Hz- 1min)
2. Max power dissipation at +125°C: 400mW
3. Heat increase at Max current ≤25°C
4. 1:1 ratio (sector wound construction)
5. Interwinding capacitances <15 pF
6. Variation of «L» values over the working temperature range ≤15%
7. Admissible temp. during reflow soldering : +260°C / 30 seconds

Typical Dimensions (mm, top view)

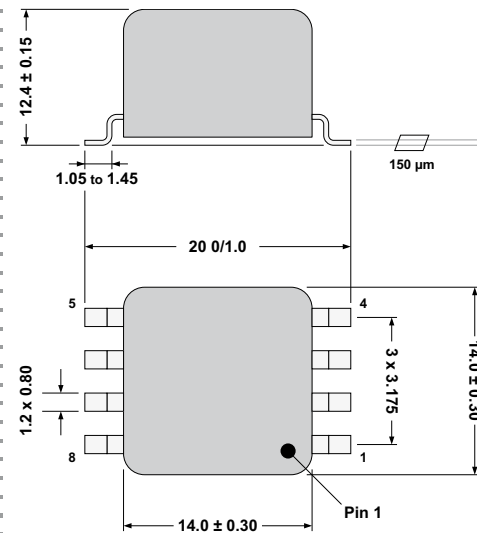

Connections

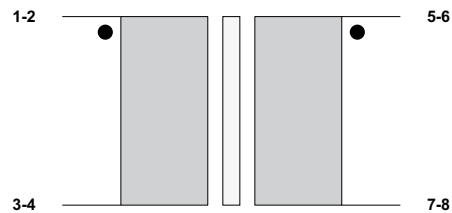

PCB Layout (suggested)

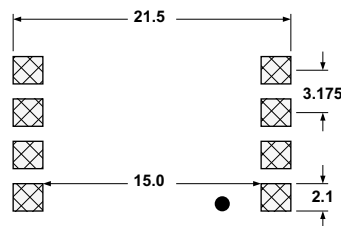

Packaging

Tape and Reel:
200 units per reel of diameter 330 mm

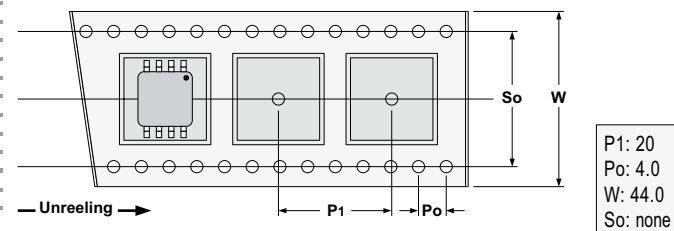

Marking

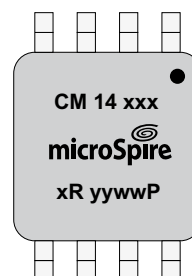

yyww :
Date code

High Grade Technologies...
Power Magnetics...
Common Mode Chokes...

CMC 17 Common Mode Chokes Series

High Grade - Improved Temperature Stability



- Less than 20% performance variations versus temperature (-55 °C/ +125 °C)
- Minimum impedance attenuation : 100 Ω from 100 kHz to 30 MHz
- Compact SMD package (2x4 pins)
- Applied standards : MIL-STD-202, ECSS-Q-ST-70-02C, DO-160 and ESCC 3201 generic specification for space products
- RMS current range : from 1.1 A to 11.7 A for 40 °C heating above 25 °C
- Materials meet UL94-V0 rating
- Thermal index according to IEC85 : H (180 °C)
- Operating/storage temperature range : -55 °C to +125 °C
- Approx weight : 10 grams

Electrical Data

ID Code	Inductance Value at 25°C (-40/+35%)	Typical SRF	Max Impedance (Typical)	Max Attenuation (Z = 50Ω)	MAX RMS Current for ΔT = 40°C	MAX DC Resistance (25°C)	Typical Leakage Inductance (100kHz)
CMC17 M45 1WR	0.45 mH	32 MHz	1 kΩ	20 dB	11.7 A	5 mΩ	0.5 μH
CMC17 1M2 1WR	1.15 mH	15 MHz	1.9 kΩ	26 dB	8.3 A	10 mΩ	1.1 μH
CMC17 2M6 1WR	2.59 mH	8 MHz	3.7 kΩ	32 dB	6 A	18 mΩ	2.3 μH
CMC17 5M8 1WR	5.83 mH	1.5 MHz	5.3 kΩ	35 dB	4 A	40 mΩ	6.3 μH
CMC17 13M 1WR	13.1 mH	0.6 MHz	9.4 kΩ	40 dB	2.7 A	90 mΩ	13.4 μH
CMC17 30M 1WR	30.3 mH	0.3 MHz	15.8 kΩ	44 dB	1.7 A	220 mΩ	32 μH
CMC17 69M 1WR	69.2 mH	0.1 MHz	29 kΩ	49 dB	1.1 A	500 mΩ	70 μH

Typical Dimensions (mm, top view)

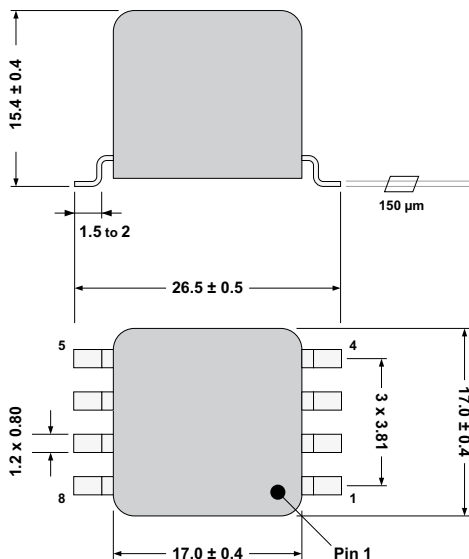

Notes

1. Dielectric strength test : 500v (50Hz - 1min)
2. 1:1 ratio (sector wound construction)

Connections

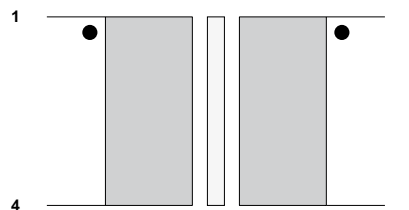

PCB Layout (suggested)

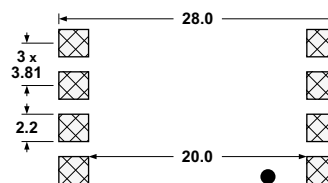

Packaging

Tape and Reel:
 150 units per reel of diameter 330 mm

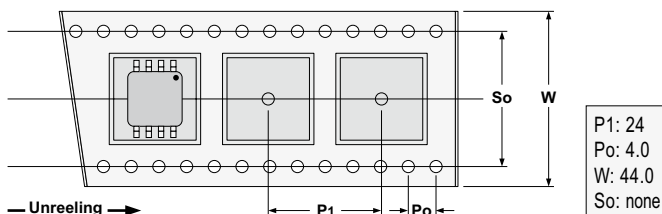

Marking

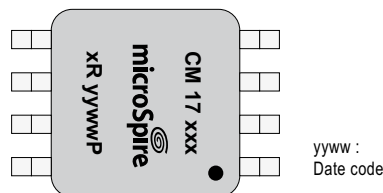

.....High Grade Technologies.....
 ...Power Magnetics.....
 ...Common Mode Chokes..



CMC 17 Common Mode Chokes Series

High Grade - Improved Temperature Stability

High Grade Technologies...
 Power Magnetics...
 Common Mode Chokes...

Impedance

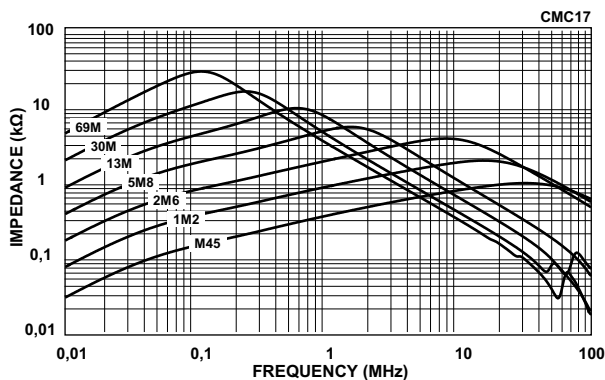

Typical values at 25°C with 1mT at 10kHz

Attenuation

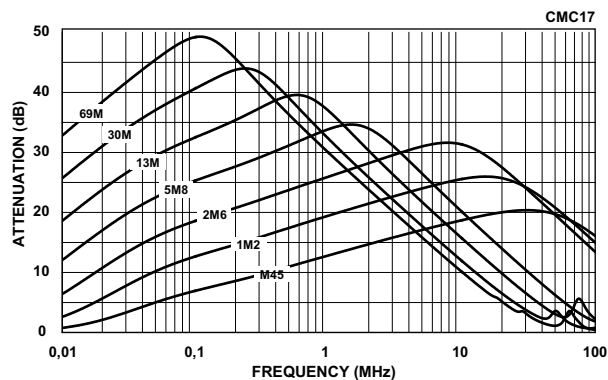

Typical values (Z=50Ω) at 25°C with 1mT at 10kHz

Variation vs Temperature

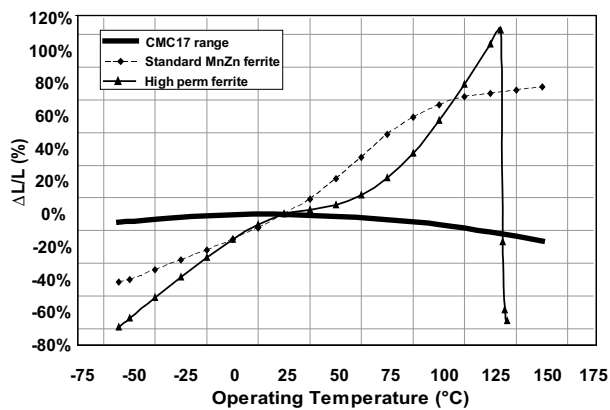

Change in inductance value (<1mT at 10kHz)

Attenuation Measurement Circuit

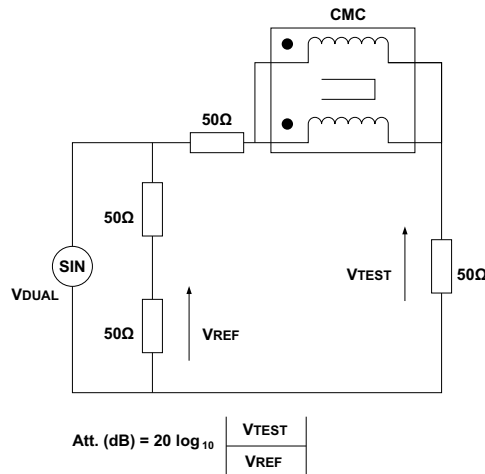

CMC17 range uses very high performance materials and therefore, offers remarkable temperature stability figures compared to standard or high-perm ferrite cores.



CMC 17 Common Mode Chokes Series

High Grade - Improved Temperature Stability

Derating Curves

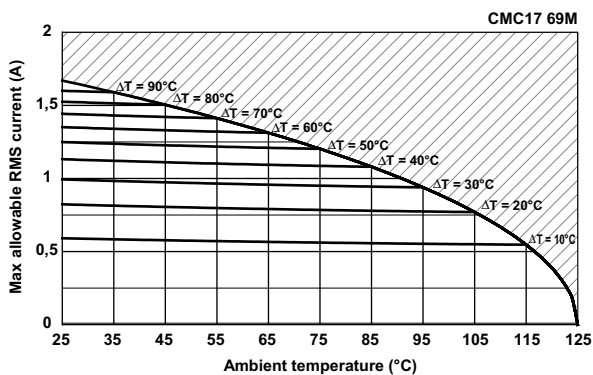
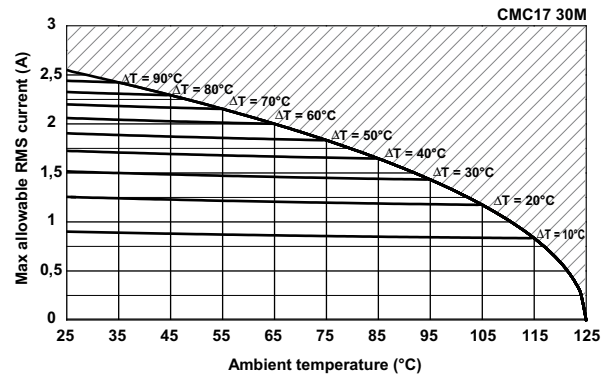
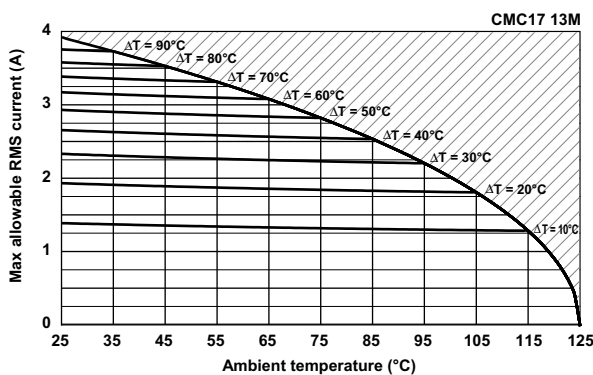
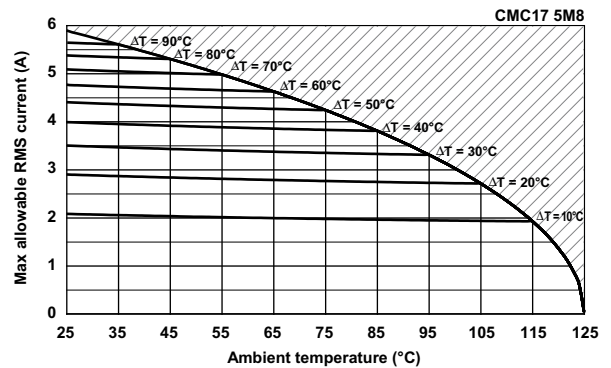
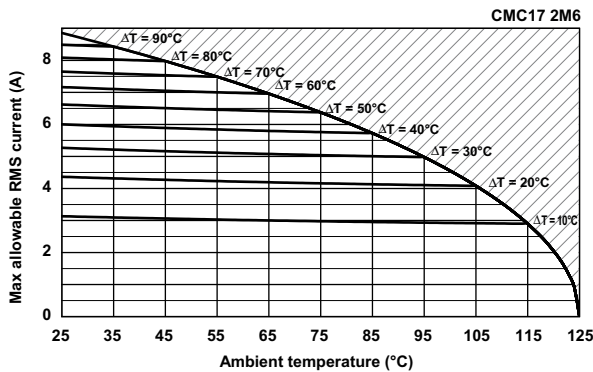
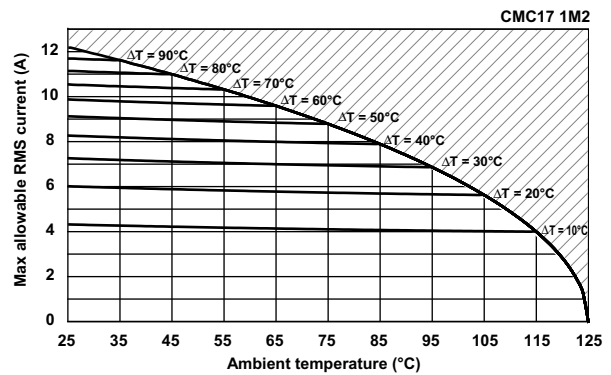
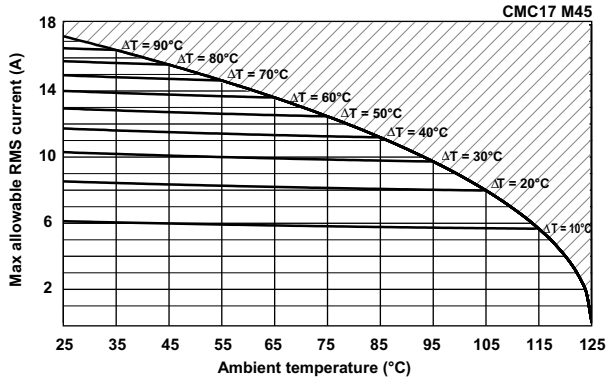

All thermal measurements under atmospheric conditions with component mounted on 1 dm² PCB without cooling device. All above graphs indicate maximum RMS current allowed through component v. ambient temperature for a defined ΔT. Maximum operating temperature is +125 °C.

Example:

CMC17 M45 for application with T_{amb} = + 85 °C Max current allowed is <11Arms with ΔT<40 °C. If temp increase allowed in application is limited to ΔT<20 °C, current must be reduced to 8 Arms.

High Grade Technologies...
 Power Magnetics...
 Common Mode Chokes...

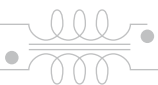

Technical note - Appendix

CMC 15 - 18 - 22 & CMC 17 Temperature Application



- The operating temperature announced in the datasheets takes into account maximum ambient temperature around the component + its self heating temperature in operation.
- Typical T° range is -55°C +125°C for usual embedded applications (avionics, defence, space...) in order to ensure a good ageing of the products.
- Microspire guarantees an extended lifetime in this operational T° range, because only high temperature class materials are used and offer sufficient safety margin: all plastic materials used are H class according to IEC85 standard (180°C during 20.000 hours) and magnetic cores show a high Curie temperature value (T_c>200°C).
- Typical values for admissible current at +25°C ambient for a 40°C nominal temperature increase are defined without any heatsink in our literature.
- When using an appropriate cooling device, these values can be slightly increased
- The associated derating curves allow to check maximum current possible in the component versus acceptable temperature increase above ambient temperature of the application.

Example

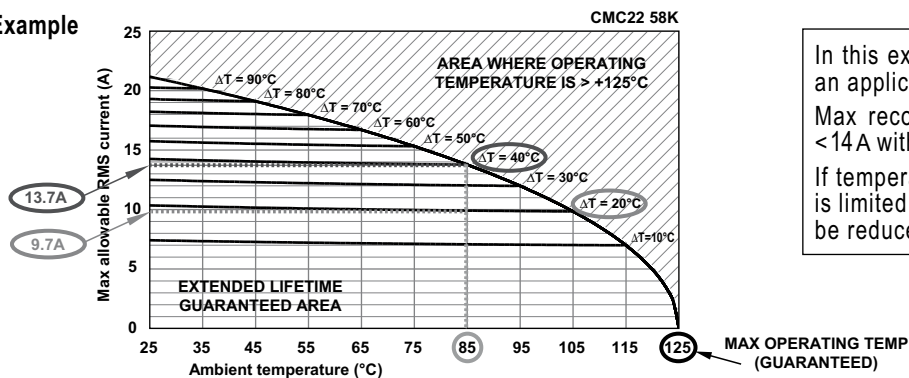

In this example, CMC2258K is chosen for an application at T_{amb} = +85°C. Max recommended RMS current is then <14 A with ΔT < 40°C. If temperature increase in the application is limited to ΔT < 20°C, current value must be reduced to <10 A.

- With the above data, it is clear that the « theoretical » maximum possible current reaches zero for +125°C ambient temperature (because heating above is not recommended) !
- However, it still remains possible to load the component with current leading to operating temperature greater than +125°C but in this case, extended lifetime for the product is not guaranteed any longer.
- Heating values versus current above +125°C operating temperature can still be calculated upon request.



Build-to-print Rotors and Stators manufacturing



- Stators, rotors, from 10 to 120mm
- DC-brushless motors, servo motors, linear motors
- High temperature products:
 - Raw Material
 - Impregnation Process

Operations

1. Design and manufacturing of the specific armature tools
2. Armatures or stator stacks gluing under pressure and varnishing laminations on stacking fixtures
3. Sets of coil winding operations

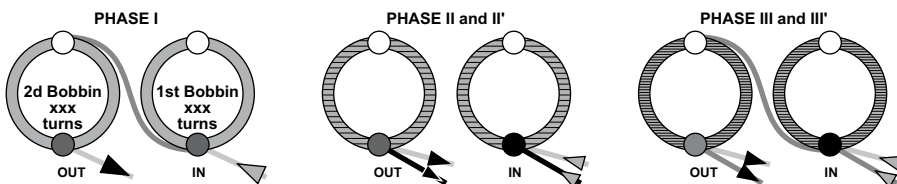

4. Slot insulation positioning, winding insertion into the armature slot, cutting down and folding slot insulation and inserting wedges as each slot is filled.

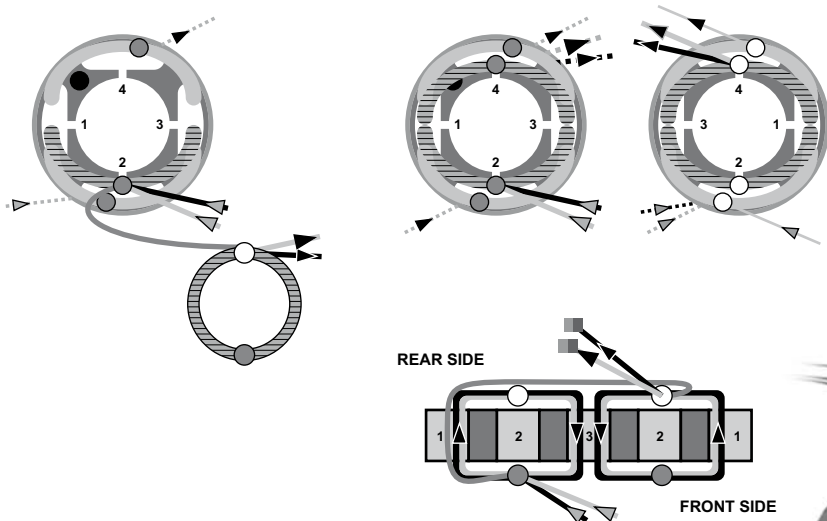

5. Cabling of leadwire with Teflon isolated and flexible sleeve wire, inter-connection of several windings
6. Windings binding and forming against final mechanical dimensions
7. Securing position with lancing tape
8. External rectifying of rotor stacks, internal eroding of stator stacks, notch milling, boring
9. Assembling of the collector and cabling of the winding wires



..... High Grade Technologies.....
 Custom Designs.....

